

# Feeder Rebuild Program

For Extreme Duty Rotary Valves

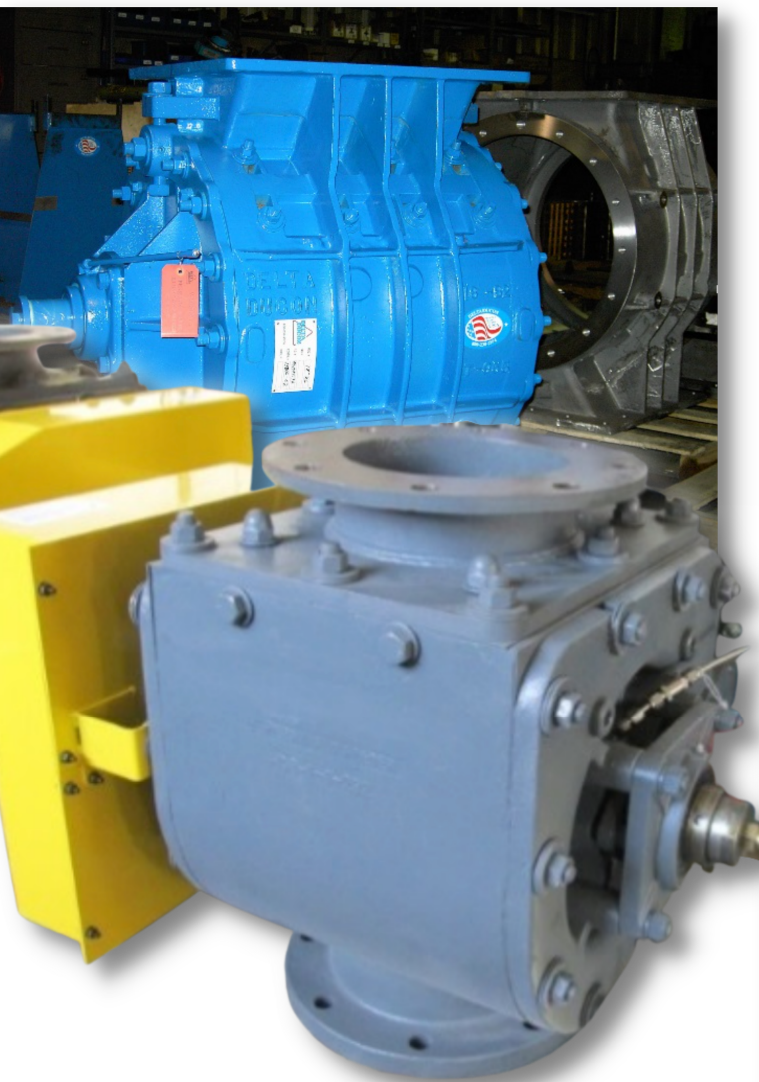

Our PERMA/flo "XT & XL" Extreme Rotary Valve has been considered the valve of choice by customers who demand long life, rugged durability, ease of maintenance and high quality.

Though these rotary valves have been known to last five times the life of our competitors, there will come the time when repair or rebuilding is necessary.

Delta Ducon has an MRO based rebuild program that will evaluate, regrind or repair your XT and XL rotary valve to reduce down time and make it perform like new again.

Because the rotor and seal shoe of the XT and XL rotary valves are heavy castings, constructed of a special P-33 chrome-iron alloy that yields a hardness of 500-600 Brinell, Delta Ducon is can regrind these parts to provide the tight clearance required for your application.



Other valves typically feature a surface hardening that wears away to expose a softer metal base. Once worn these types of valves are often thrown away.

From minor repair to complete rebuilding, Delta Ducon has a Rebuild Program to meet your MRO requirements and limit downtime. Contact us for all your rotary valves needs.

**Delta Ducon**

11 General Warren Blvd, Malvern PA 19355

Phone: 610.695-9700 Fax: 610.695.9724

[www.deltaducon.com](http://www.deltaducon.com)



# Feeder Rebuild Program

For Extreme Duty Rotary Valves

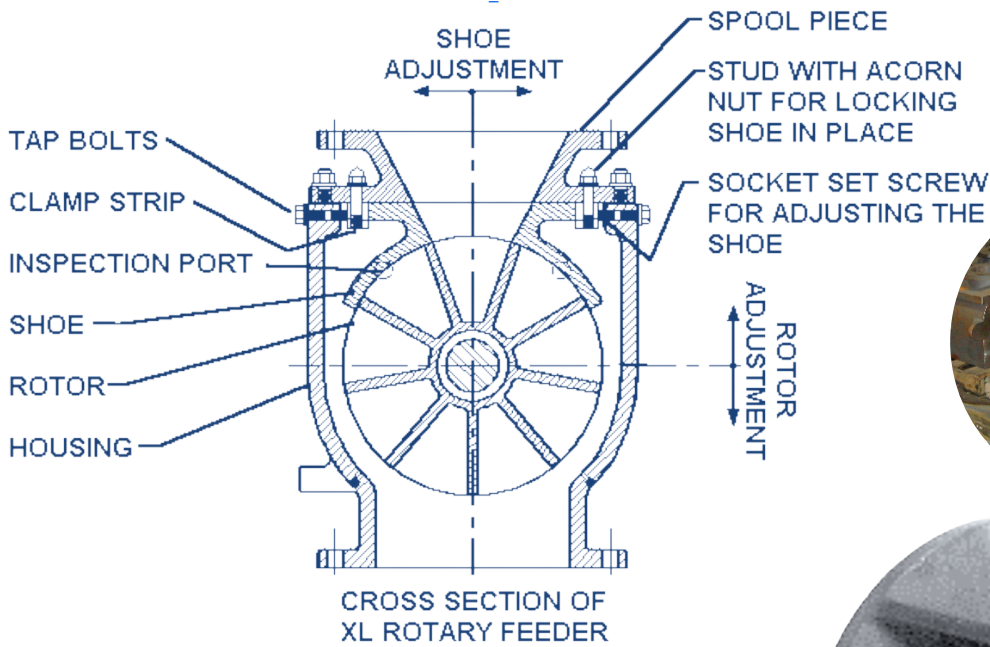

Inspections, Regrinding, assembly, parts, painting testing. Delta Ducon provides full rotary feeder MRO support through our Feeder Rebuild Program.

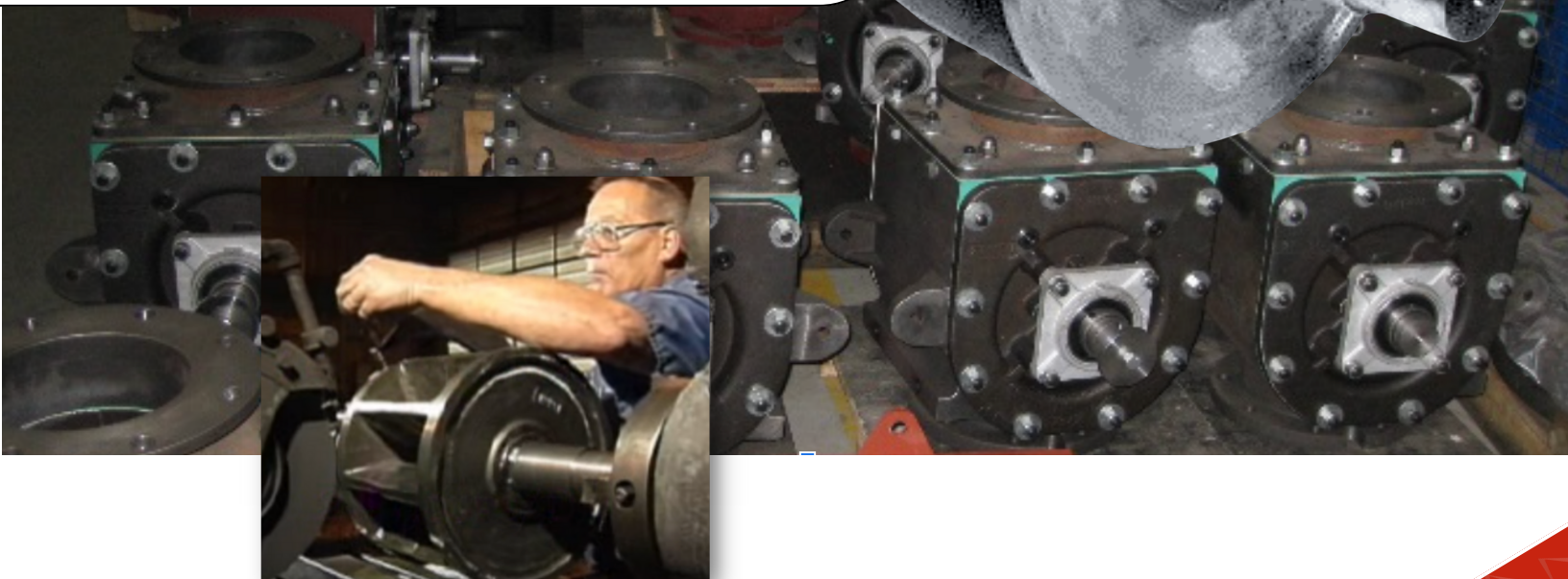
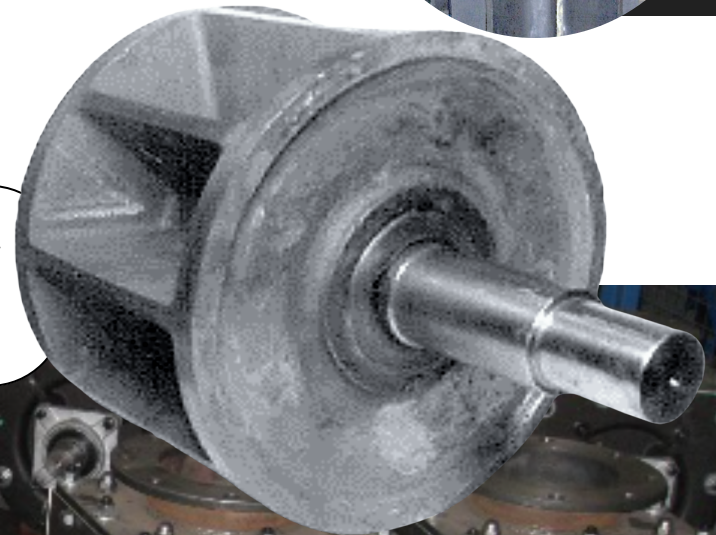

Delta Ducon  
11 General Warren Blvd, Malvern PA 19355  
Phone: 610.695-9700 Fax: 610.695.9724  
[www.deltaducon.com](http://www.deltaducon.com)

